

SPECIFICATION
FOR
LCM Module

MODULE No:	KD101WXFLD021-01
CUSTOMER:	

STARTEK	INITIAL	DATE
PREPARED BY		
CHECKED BY		
APPROVED BY		

CUSTOMER	INITIAL	DATE
APPROVED BY		

Part. No	KD101WXFLD021-01	REV	V1.1	Page 1 of 25
----------	------------------	-----	------	--------------

常备库存
Stock For Sale

长期供货
Long Time supply

支持小量
NO MOQ

品种齐全
In Full Range



Revision History

Date	Rev. No.	Page	Summary
2022.07.14	V1.0	ALL	FIRST ISSUE
2023.06.13	V1.1	4,6	Change driver chip

Contents

1. Block Diagram	5
2. Outline dimension	6
3. Input terminal Pin Assignment	7
4. LCD Optical Characteristics	9
4.1 Optical specification	9
5. Electrical Characteristics	12
5.1 Absolute Maximum Rating	12
5.2 DC Electrical Characteristics	12
5.3 LED Backlight Characteristics	13
6. Video Interface and Timing Table	15
6.1 LVDS interface	15
6.1.1 Data input format for LVDS	15
6.1.2 LVDS Input Timing Table	16
For 1280RGBx800	16
7. LCD Module Out-Going Quality Level	17
7.1 VISUAL & FUNCTION INSPECTION STANDARD	17
7.1.1 Inspection conditions	17
7.1.3 Sampling Plan	18
7.1.4 Criteria (Visual)	19
8. Reliability Test Result	23
9. Cautions and Handling Precautions	24
9.1 Handling and Operating the Module	24
9.2 Storage and Transportation	24
10. Packing	25

Part. No	KD101WXFLD021-01	REV	V1.1	Page 3 of 25
	常备库存 Stock For Sale	长期供货 Long Time supply	支持少量 NO MOQ	品种齐全 In Full Range

*** Description**

This is a color active matrix TFT (Thin Film Transistor) LCD (liquid crystal display) that uses amorphous silicon TFT as a switching device. This module is composed of a Transmissive type TFT-LCD Panel, driver circuit, back-light unit. The resolution of a 10.1 " TFT-LCD contains 1280x800 pixels, and can display up to 16.7M colors.

*** Features**

General Information Items	Specification	Unit	Note
	Main Panel		
Display area(AA)	216.96(H)*135.6(V) (10.1 inch)	mm	
Driver element	TFT active matrix	-	
Display colors	16.7M	colors	
Number of pixels	1280(RGB)*800	dots	
Pixel arrangement	RGB vertical stripe	-	
Pixel pitch	0.1692(H)*0.1692(V)	mm	
Viewing angle	ALL	o'clock	
Controller IC	EK79202D_A	-	
LCM Interface	8 BIT LVDS	-	
Display mode	Transmissive /Normally Black	-	
Operating temperature	-20~+70	°C	
Storage temperature	-30~+85	°C	

*** Mechanical Information**

Item		Min.	Typ.	Max.	Unit	Note
Module size	Horizontal(H)	-	229.06	-	mm	
	Vertical(V)	-	148.70	-	mm	
	Depth(D)	-	2.56	-	mm	
Weight		-	210	-	g	

1. Block Diagram

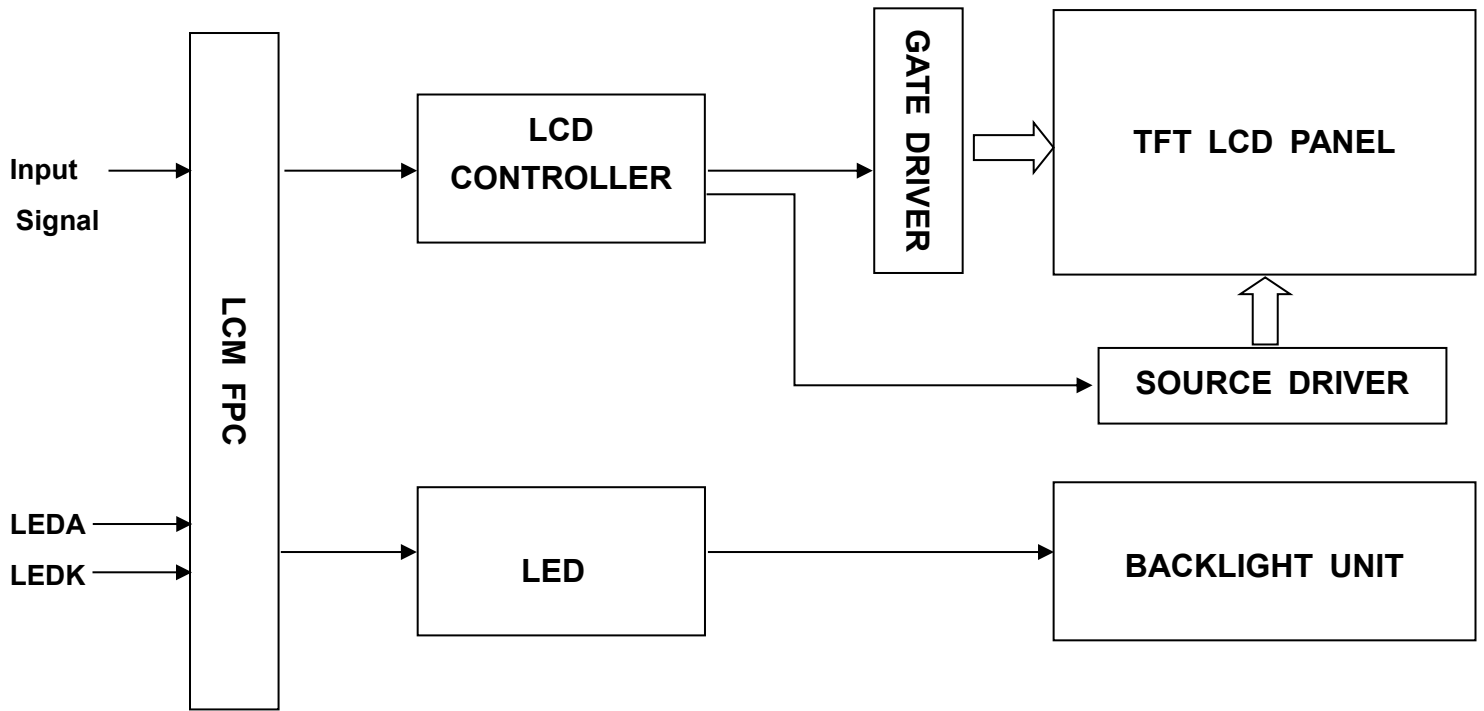

Part. No	KD101WXFLD021-01	REV	V1.1	Page 5 of 25
常备库存 Stock For Sale	长期供货 Long Time supply	支持小量 NO MOQ	品种齐全 In Full Range	

2. Outline dimension

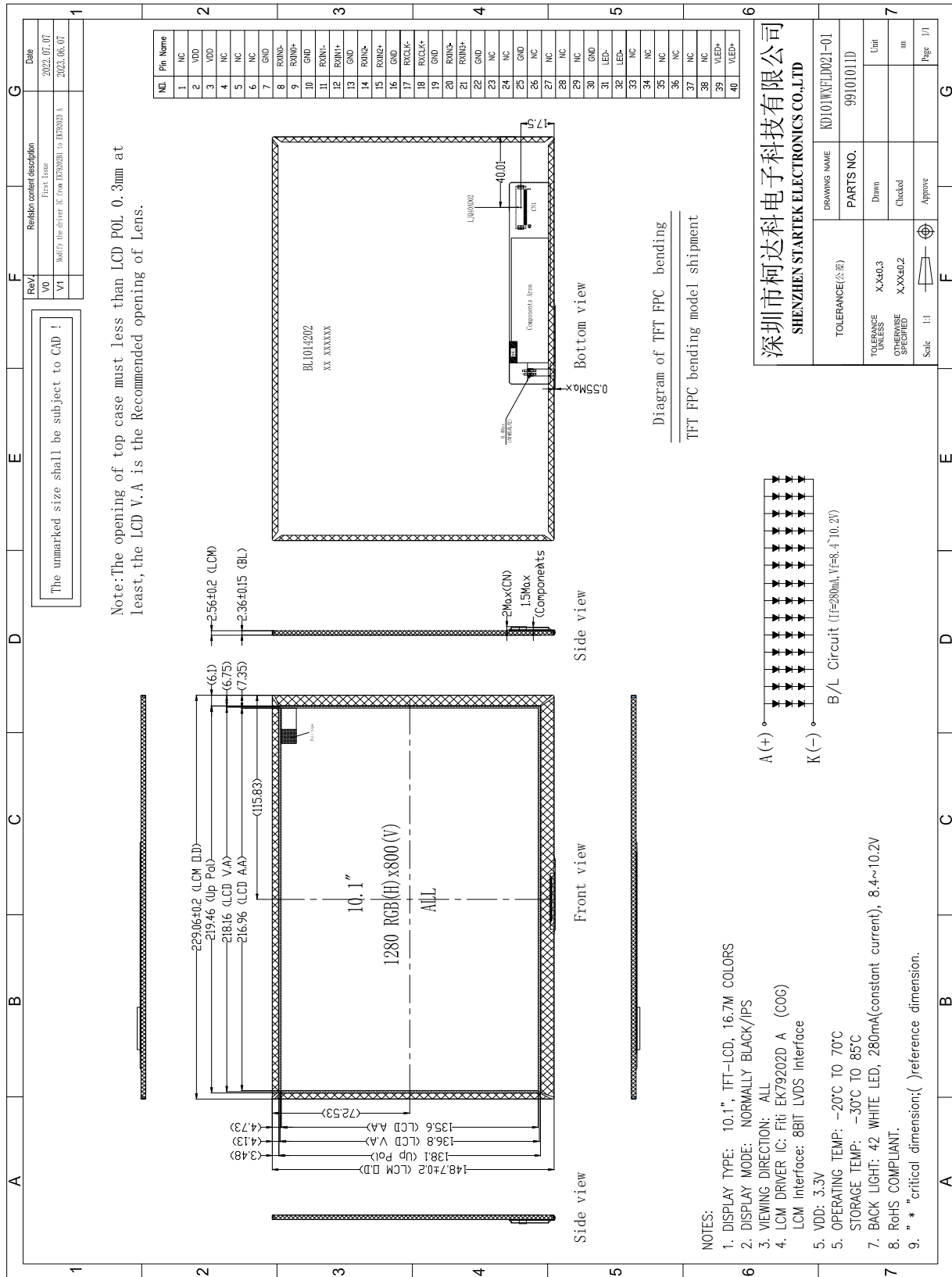

Part. No	KD101WXFLD021-01	REV	V1.1	Page 6 of 25
----------	------------------	-----	------	--------------

常备库存
Stock For Sale

长期供货
Long Time supply

支持小量
NO MOQ

品种齐全
In Full Range

3. Input terminal Pin Assignment

40pin connector is used for the module electronics interface. The recommended model is Molex_505110-4096 manufactured by Molex.

NO.	SYMBOL	DISCRIPTION	I/O
1	NC	--	--
2	VDD	A power supply for analog circuit. VDD=3.3V;	P
3	VDD		
4	NC	--	--
5	NC	--	--
6	NC	--	--
7	GND	Ground	P
8	RXIN0-	-LVDS Differential Data Input	I
9	RXIN0+	+LVDS Differential Data Input	I
10	GND	Ground	P
11	RXIN1-	-LVDS Differential Data Input	I
12	RXIN1+	+LVDS Differential Data Input	I
13	GND	Ground	P
14	RXIN2-	-LVDS Differential Data Input	I
15	RXIN2+	+LVDS Differential Data Input	I
16	GND	Ground	P
17	RXCLK-	-LVDS Differential Clock Input	I
18	RXCLK+	+LVDS Differential Clock Input	I
19	GND	Ground	P
20	RXIN3-	-LVDS Differential Data Input	I
21	RXIN3+	+LVDS Differential Data Input	I
22	GND	Ground	P
23	NC	--	--
24	NC	--	--
25	GND	Ground	P
26	NC	--	--
27	NC	--	--
28	NC	--	--
29	NC	--	--
30	NC	--	--
31	LED-	LED Cathode	P

Part. No	KD101WXFLD021-01	REV	V1.1	Page 7 of 25
----------	------------------	-----	------	--------------

常备库存
Stock For Sale

长期供货
Long Time supply

支持小量
NO MOQ

品种齐全
In Full Range

32	LED-	LED Cathode	P
33	NC	--	--
34	NC	--	--
35	NC	--	--
36	NC	--	--
37	NC	--	--
38	NC	--	--
39	LED+	LED Anode	P
40	LED+	LED Anode	P

4. LCD Optical Characteristics

4.1 Optical specification

Item	Symbol	Condition	Min.	Typ.	Max.	Unit.	Note
Contrast Ratio	CR	$\Theta=0$	800	1000	--		CA-310
Response time	Rising	T_{R+T_F}	--	25	35	msec	*
	Falling						*
Uniformity	S(%)		42	45	--	%	*
Color Filter Chromaticity ((CIE 1931))	White	W_X	-0.04	0.3185	+0.04		CA-310
		W_Y		0.3434			
	Red	R_X		0.5916			
		R_Y		0.3594			
	Green	G_X		0.3624			
		G_Y		0.5525			
	Blue	B_X		0.1484			
		B_Y		0.1084			
Viewing angle	Hor.	Θ_L	CR>10	70	80	--	*
		Θ_R		70	80	--	
	Ver.	Θ_U		70	80	--	
		Θ_D		70	80	--	
Option View Direction	ALL						

* The data comes from the LCD specification.

Measuring Condition

Measuring surrounding : dark room

Ambient temperature : $25\pm 2^\circ\text{C}$

15min. warm-up time.

Measuring Equipment

FPM520 of Westar Display technologies, INC., which utilized SR-3 for Chromaticity and BM-5A for other optical characteristics.

Part. No	KD101WXFLD021-01	REV	V1.1	Page 9 of 25
----------	------------------	-----	------	--------------

常备库存
Stock For Sale

长期供货
Long Time supply

支持小量
NO MOQ

品种齐全
In Full Range

Note (1): Definition of Viewing Angle :

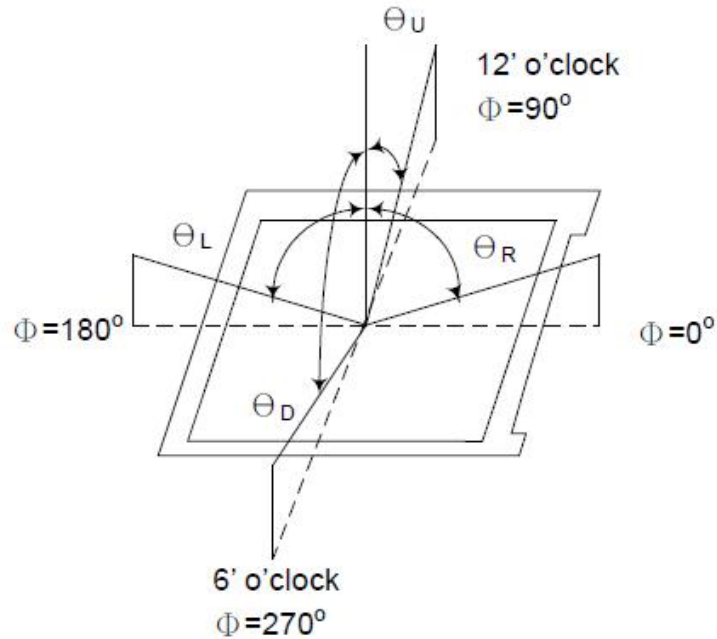

Note (2): Definition of Contrast Ratio(CR) :measured at the center point of panel

$$CR = \frac{\text{Luminance with all pixels white}}{\text{Luminance with all pixels black}}$$

Note (3): Response Time

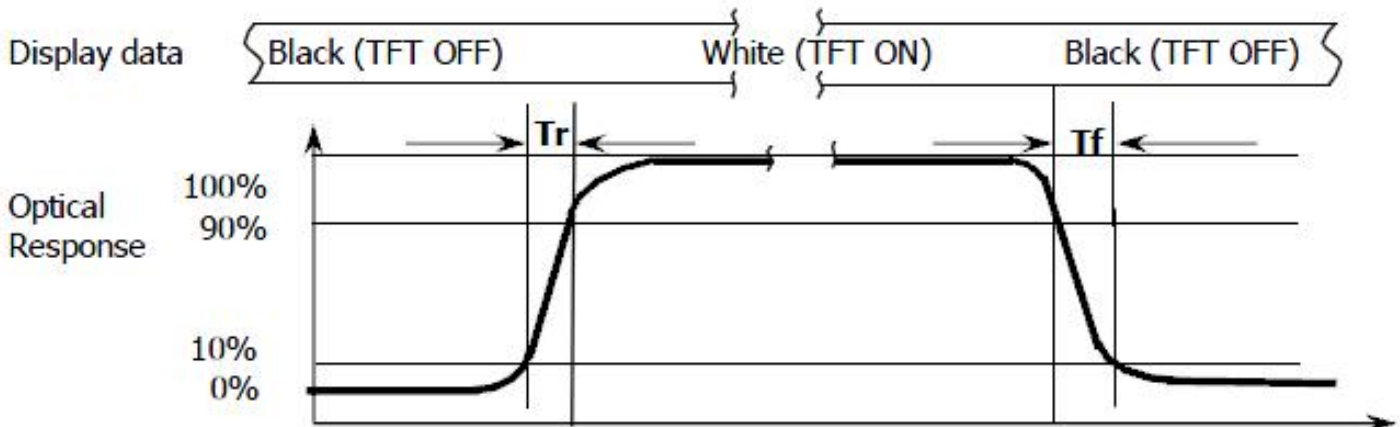

Part. No	KD101WXFLD021-01	REV	V1.1	Page 10 of 25
常备库存 Stock For Sale	长期供货 Long Time supply	支持小量 NO MOQ	品种齐全 In Full Range	

Note (4): Definition of optical measurement setup

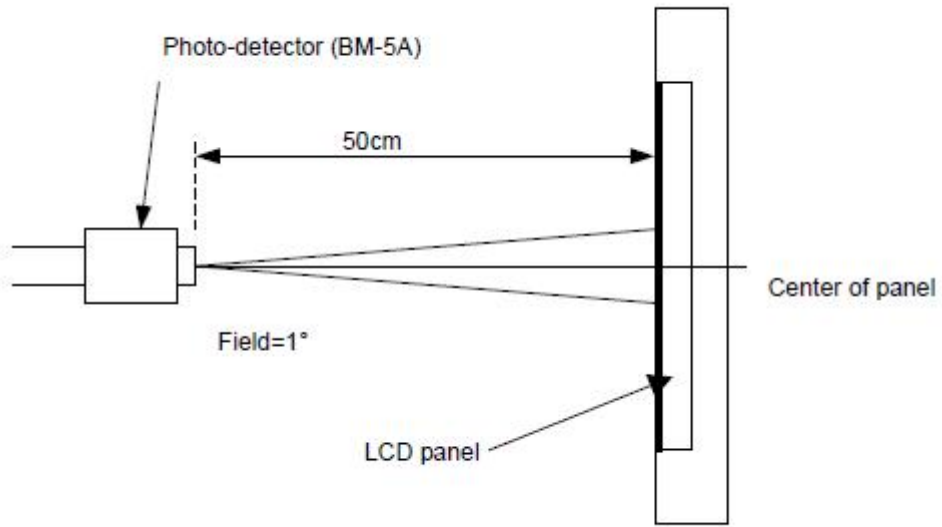

Part. No	KD101WXFLD021-01	REV	V1.1	Page 11 of 25
常备库存 Stock For Sale	长期供货 Long Time supply	支持小量 NO MOQ	品种齐全 In Full Range	

5. Electrical Characteristics

5.1 Absolute Maximum Rating

Characteristics	Symbol	Min.	Max.	Unit	Note
Digital Supply Voltage	VDD	-0.5	4	V	Note1
Operating temperature	T _{OP}	-20	+70	°C	
Storage temperature	T _{ST}	-30	+85	°C	

NOTE1: If the absolute maximum rating of even is one of the above parameters is exceeded even momentarily, the quality of the product may be degraded. Absolute maximum ratings, therefore, specify the values exceeding which the product may be physically damaged. Be sure to use the product within the range of the absolute maximum ratings.

5.2 DC Electrical Characteristics

Characteristics	Symbol	Min.	Typ.	Max.	Unit	Note
Digital Supply Voltage	VDD	-	3.3	-	V	
Normal mode Current	IDD	--	170	340	mA	
Level input voltage	V _{IH}	0.8*VDD	--	VDD	V	
	V _{IL}	GND	--	0.2*VDD	V	

Part. No	KD101WXFLD021-01	REV	V1.1	Page 12 of 25
----------	------------------	-----	------	---------------

常备库存
Stock For Sale

长期供货
Long Time supply

支持小量
NO MOQ

品种齐全
In Full Range

5.3 LED Backlight Characteristics

The back-light system is edge-lighting type with 42 chips LED

Item	Symbol	Min.	Typ.	Max.	Unit	Note
Forward Current	I_F	--	280	--	mA	
Forward Voltage	V_F	--	9.6	--	V	
LCM Luminance	LV	550	650	--	cd/m ²	
LED life time	Hr	50000	--	--	Hour	Note1,2
Uniformity	Avg	70	80	--	%	Note3

Note1: LED life time (Hr) can be defined as the time in which it continues to operate under the condition:

$T_a=25\pm3\text{ }^\circ\text{C}$, typical IL value indicated in the above table until the brightness becomes less than 50%.

Note 2: The "LED life time" is defined as the module brightness decrease to 50% original brightness at

$T_a=25\text{ }^\circ\text{C}$ and $I_L=280\text{mA}$. The LED lifetime could be decreased if operating I_L is larger than 280mA. The constant current driving method is suggested.

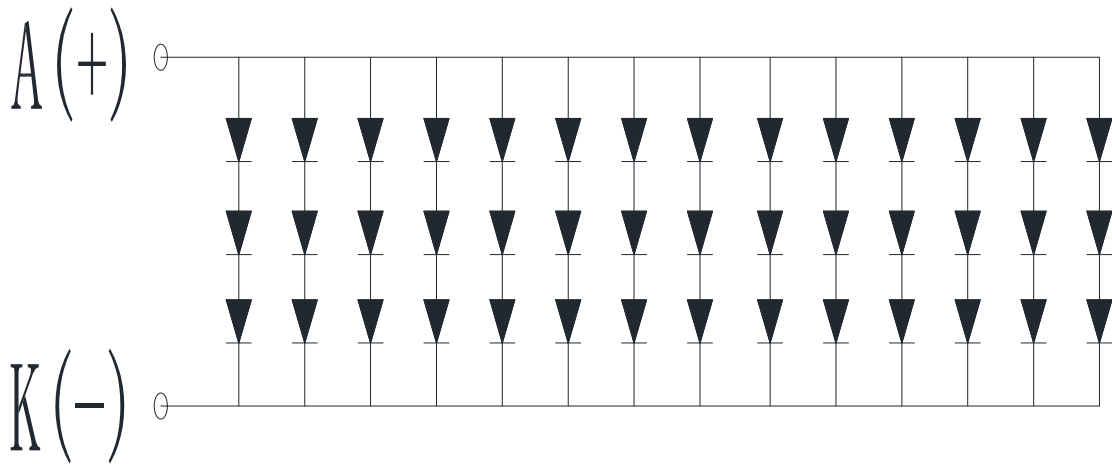

B/L Circuit ($I_f=280\text{mA}$, $V_f=8.4\sim 10.2\text{V}$)

Part. No	KD101WXFLD021-01	REV	V1.1	Page 13 of 25
----------	------------------	-----	------	---------------

常备库存
Stock For Sale

长期供货
Long Time supply

支持小量
NO MOQ

品种齐全
In Full Range

Note (3) Luminance Uniformity of these 9 points is defined as below:

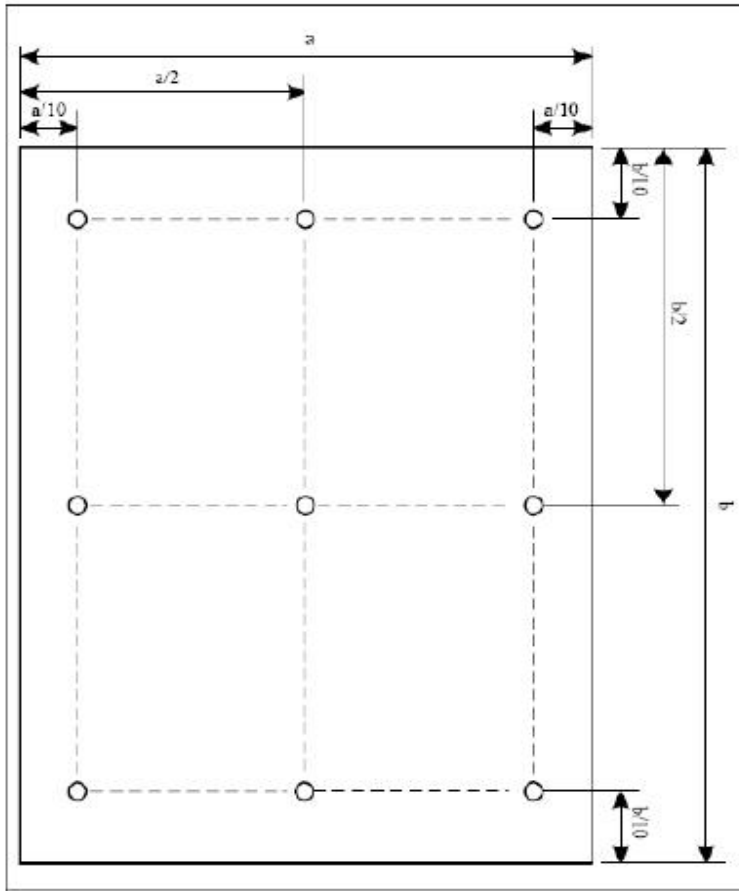

$$\text{Uniformity} = \frac{\text{minimum luminance in 9 points (1-9)}}{\text{maximum luminance in 9 points (1-9)}}$$

$$\text{Luminance} = \frac{\text{Total Luminance of 9 points}}{9}$$

Part. No	KD101WXFLD021-01	REV	V1.1	Page 14 of 25
常备库存 Stock For Sale	长期供货 Long Time supply	支持小量 NO MOQ	品种齐全 In Full Range	

6. Video Interface and Timing Table

6.1 LVDS interface

6.1.1 Data input format for LVDS

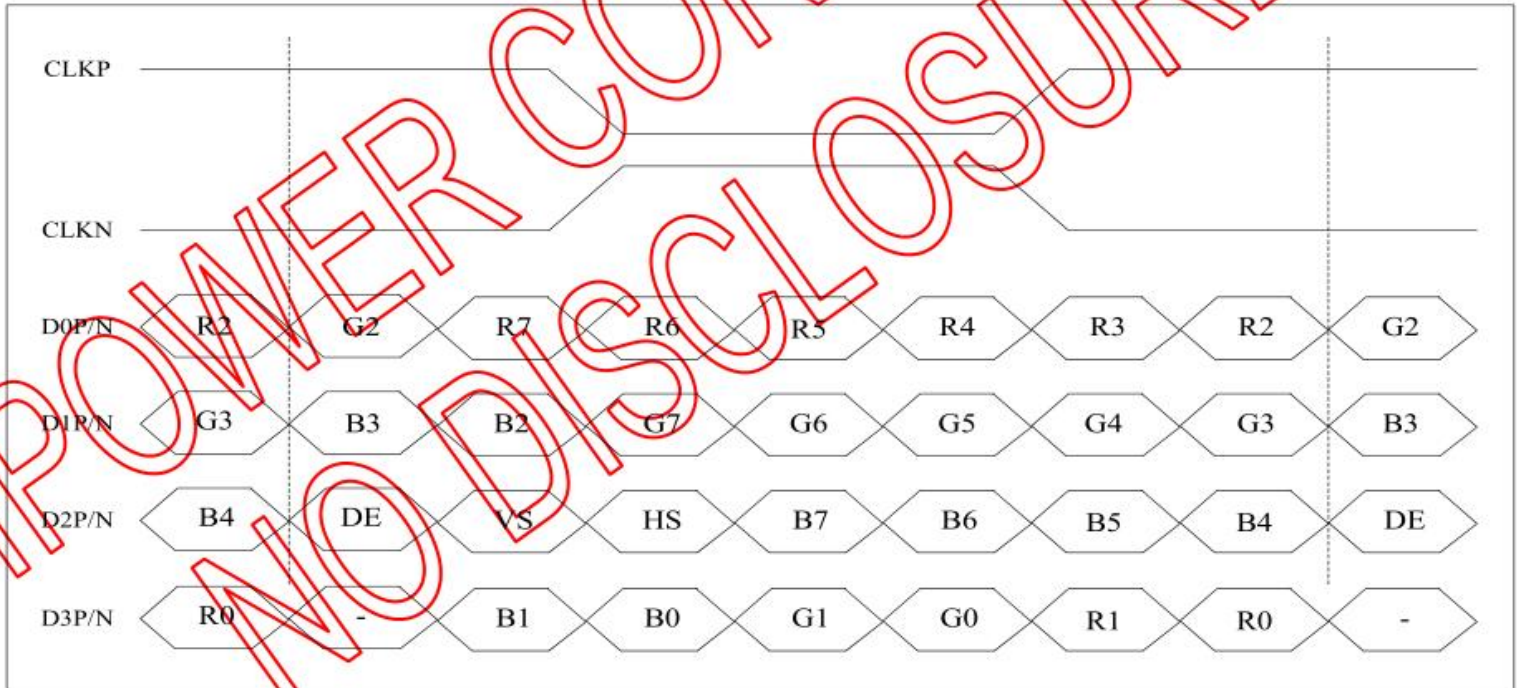

8-bit LVDS input (LVBIT=H, LVFMT=L)

Part. No	KD101WXFLD021-01	REV	V1.1	Page 15 of 25
----------	------------------	-----	------	---------------

常备库存
Stock For Sale

长期供货
Long Time supply

支持少量
NO MOQ

品种齐全
In Full Range

6.1.2 LVDS Input Timing Table

For 1280RGBx800

Parameter	Symbol	Value			Unit
		Min.	Typ.	Max.	
DCLK frequency @Frame rate=60Hz (LVDS)	F _{DCLK}	66.3	72.4	78.9	MHz
HSYNC period time	T _H	1380	1440	1500	DCLK
Horizontal display area	T _{HD}	1280			DCLK
HSYNC pulse width	T _{HPW}	Min.	2		
		Typ.	-		
		Max.	40		
HSYNC back porch(with pulse width)	T _{HBP}	88	88	88	DCLK
HSYNC front porch	T _{HFP}	12	72	132	DCLK
VSYNC period time	T _V	824	838	872	H
Vertical display area	T _{VD}	800			H
VSYNC pulse width	T _{VPW}	Min.	2		H
		Typ.	-		
		Max.	20		
VSYNC back porch(with pulse width)	T _{VBP}	23	23	23	H
VSYNC front porch	T _{VFP}	1	15	49	H

Part. No	KD101WXFLD021-01	REV	V1.1	Page 16 of 25
----------	------------------	-----	------	---------------

常备库存
Stock For Sale

长期供货
Long Time supply

支持少量
NO MOQ

品种齐全
In Full Range

7. LCD Module Out-Going Quality Level

7.1 VISUAL & FUNCTION INSPECTION STANDARD

7.1.1 Inspection conditions

Inspection performed under the following conditions is recommended.

Temperature : $25\pm 5^{\circ}\text{C}$

Humidity : $65\%\pm 10\%\text{RH}$

Viewing Angle : Normal viewing Angle.

Illumination: Single fluorescent lamp (300 to 700Lux)

Viewing distance:30-50cm

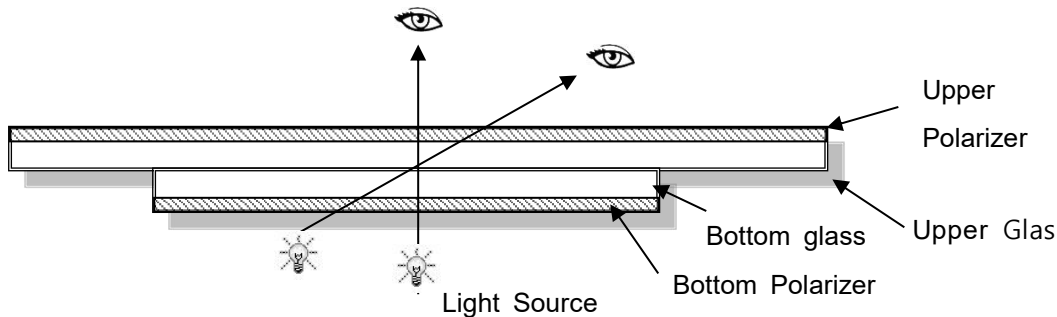

7.1.2 Definition

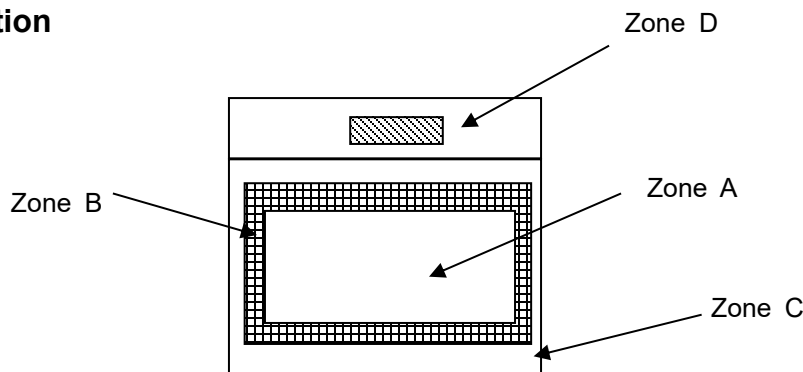

Zone A : Effective Viewing Area(Character or Digit can be seen)

Zone B : Viewing Area except Zone A

Zone C : Outside (Zone A+Zone B) which can not be seen after assembly by customer .)

Zone D : IC Bonding Area

Note:As a general rule ,visual defects in Zone C can be ignored when it doesn't effect product function or appearance after assembly by customer

Part. No	KD101WXFLD021-01	REV	V1.1	Page 17 of 25
常备库存 Stock For Sale	长期供货 Long Time supply	支持小量 NO MOQ	品种齐全 In Full Range	

7.1.3 Sampling Plan

According to GB/T 2828.1-2003 ; , normal inspection, Class II

AQL:

Major defect	Minor defect
0.65	1.5

LCD: Liquid Crystal Display , TP: Touch Panel , LCM: Liquid Crystal Module

No	Items to be inspected	Criteria	Classification of defects
1	Functional defects	1) No display, Open or miss line 2) Display abnormally, Short 3) Backlight no lighting, abnormal lighting.	Major
2	Missing	Missing component	
3	Outline dimension	Overall outline dimension beyond the drawing is not allowed	
4	Color tone	Color unevenness, refer to limited sample	Minor
5	Spot Line defect	Light dot, Dim spot, Polarizer Bubble ; Polarizer accidented spot.	
6	Soldering appearance	Good soldering , Peeling off is not allowed.	
7	LCD/Polarizer	Black/White spot/line, scratch, crack, etc.	

Note1: a) Light dot: Dots appear bright and unchanged in size in which LCD panel is displaying under black pattern.



b) Dim dot: Dots appear dark and unchanged in size in which LCD panel is displaying under pure red, green, blue picture.

Part. No	KD101WXFLD021-01	REV	V1.1	Page 18 of 25
	常备库存 Stock For Sale	长期供货 Long Time supply	支持小量 NO MOQ	品种齐全 In Full Range

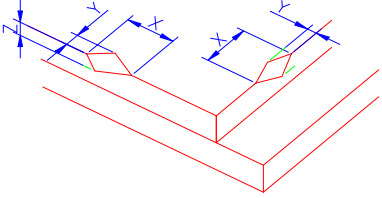
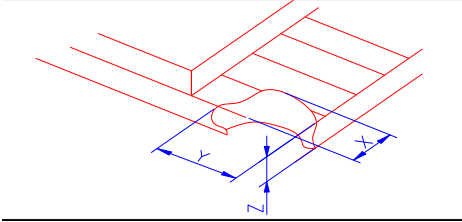
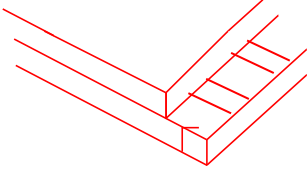
7.1.4 Criteria (Visual)

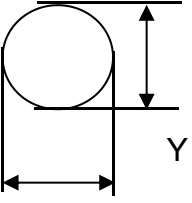
Number	Items	Criteria(mm)						
1.0 LCD Crack/Broken NOTE: X: Length Y: Width Z: Height L: Length of IT O, T: Height of LCD	(1) The edge of LCD broken	 <table border="1" data-bbox="756 667 1453 815"> <thead> <tr> <th>X</th> <th>Y</th> <th>Z</th> </tr> </thead> <tbody> <tr> <td>≤3.0mm</td> <td><Inner border line of the seal</td> <td>≤T</td> </tr> </tbody> </table>	X	Y	Z	≤3.0mm	<Inner border line of the seal	≤T
X	Y	Z						
≤3.0mm	<Inner border line of the seal	≤T						
	(2)LCD corner broken	 <table border="1" data-bbox="836 1122 1374 1223"> <thead> <tr> <th>X</th> <th>Y</th> <th>Z</th> </tr> </thead> <tbody> <tr> <td>≤3.0mm</td> <td>≤L</td> <td>≤T</td> </tr> </tbody> </table>	X	Y	Z	≤3.0mm	≤L	≤T
X	Y	Z						
≤3.0mm	≤L	≤T						
	(3) LCD crack	 <p style="text-align: center;">Crack Not allowed</p>						

2.0	Spot defect	<p>① light dot (black/white spot , pinhole, stain, etc.)</p> <table border="1"> <thead> <tr> <th rowspan="2">Zone Size (mm)</th> <th colspan="3">Acceptable Qty</th> </tr> <tr> <th>A</th> <th>B</th> <th>C</th> </tr> </thead> <tbody> <tr> <td>$\Phi \leq 0.15$</td> <td colspan="3">Ignore</td> </tr> <tr> <td>$0.15 < \Phi \leq 0.25$</td> <td colspan="3">3(distance ≥ 10mm)</td> </tr> <tr> <td>$0.25 < \Phi \leq 0.4$</td> <td colspan="3">2(distance ≥ 10mm)</td> </tr> <tr> <td>$\Phi > 0.4$</td> <td colspan="3">0</td> </tr> </tbody> </table> <p>② Dim spot (light leakage、dent、dark spot, etc)</p> <table border="1"> <thead> <tr> <th rowspan="2">Zone Size (mm)</th> <th colspan="3">Acceptable Qty</th> </tr> <tr> <th>A</th> <th>B</th> <th>C</th> </tr> </thead> <tbody> <tr> <td>$\Phi \leq 0.15$</td> <td colspan="3">Ignore</td> </tr> <tr> <td>$0.15 < \Phi \leq 0.25$</td> <td colspan="3">3(distance ≥ 10mm)</td> </tr> <tr> <td>$0.25 < \Phi \leq 0.4$</td> <td colspan="3">2(distance ≥ 10mm)</td> </tr> <tr> <td>$\Phi > 0.4$</td> <td colspan="3">0</td> </tr> </tbody> </table> <p>③ Polarizer accidented spot</p> <table border="1"> <thead> <tr> <th rowspan="2">Zone Size (mm)</th> <th colspan="3">Acceptable Qty</th> </tr> <tr> <th>A</th> <th>B</th> <th>C</th> </tr> </thead> <tbody> <tr> <td>$\Phi \leq 0.2$</td> <td colspan="3">Ignore</td> </tr> <tr> <td>$0.2 < \Phi \leq 0.5$</td> <td colspan="3">2(distance ≥ 10mm)</td> </tr> <tr> <td>$\Phi > 0.5$</td> <td colspan="3">0</td> </tr> </tbody> </table> <p>④ Polarizer Bubble</p> <table border="1"> <thead> <tr> <th rowspan="2">Zone Size (mm)</th> <th colspan="3">Acceptable Qty</th> </tr> <tr> <th>A</th> <th>B</th> <th>C</th> </tr> </thead> <tbody> <tr> <td>$\Phi \leq 0.2$</td> <td colspan="3">Ignore</td> </tr> <tr> <td>$0.2 < \Phi \leq 0.4$</td> <td colspan="3">3(distance ≥ 10mm)</td> </tr> <tr> <td>$\Phi > 0.4$</td> <td colspan="3">0</td> </tr> </tbody> </table>			Zone Size (mm)	Acceptable Qty			A	B	C	$\Phi \leq 0.15$	Ignore			$0.15 < \Phi \leq 0.25$	3(distance ≥ 10 mm)			$0.25 < \Phi \leq 0.4$	2(distance ≥ 10 mm)			$\Phi > 0.4$	0			Zone Size (mm)	Acceptable Qty			A	B	C	$\Phi \leq 0.15$	Ignore			$0.15 < \Phi \leq 0.25$	3(distance ≥ 10 mm)			$0.25 < \Phi \leq 0.4$	2(distance ≥ 10 mm)			$\Phi > 0.4$	0			Zone Size (mm)	Acceptable Qty			A	B	C	$\Phi \leq 0.2$	Ignore			$0.2 < \Phi \leq 0.5$	2(distance ≥ 10 mm)			$\Phi > 0.5$	0			Zone Size (mm)	Acceptable Qty			A	B	C	$\Phi \leq 0.2$	Ignore			$0.2 < \Phi \leq 0.4$	3(distance ≥ 10 mm)			$\Phi > 0.4$	0		
	Zone Size (mm)					Acceptable Qty																																																																																		
					A	B	C																																																																																	
	$\Phi \leq 0.15$				Ignore																																																																																			
	$0.15 < \Phi \leq 0.25$				3(distance ≥ 10 mm)																																																																																			
$0.25 < \Phi \leq 0.4$	2(distance ≥ 10 mm)																																																																																							
$\Phi > 0.4$	0																																																																																							
Zone Size (mm)	Acceptable Qty																																																																																							
	A	B	C																																																																																					
$\Phi \leq 0.15$	Ignore																																																																																							
$0.15 < \Phi \leq 0.25$	3(distance ≥ 10 mm)																																																																																							
$0.25 < \Phi \leq 0.4$	2(distance ≥ 10 mm)																																																																																							
$\Phi > 0.4$	0																																																																																							
Zone Size (mm)	Acceptable Qty																																																																																							
	A	B	C																																																																																					
$\Phi \leq 0.2$	Ignore																																																																																							
$0.2 < \Phi \leq 0.5$	2(distance ≥ 10 mm)																																																																																							
$\Phi > 0.5$	0																																																																																							
Zone Size (mm)	Acceptable Qty																																																																																							
	A	B	C																																																																																					
$\Phi \leq 0.2$	Ignore																																																																																							
$0.2 < \Phi \leq 0.4$	3(distance ≥ 10 mm)																																																																																							
$\Phi > 0.4$	0																																																																																							
																																																																																								
$\Phi = (X+Y)/2$																																																																																								

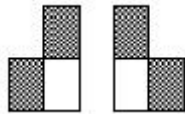
3.0	LCD Pixel defect	<p>Pixel bad points</p> <table border="1"> <thead> <tr> <th data-bbox="523 309 718 360">Item</th> <th data-bbox="718 309 1232 360">Zone A</th> <th data-bbox="1232 309 1481 360">Acceptable Qt</th> </tr> </thead> <tbody> <tr> <td data-bbox="523 360 718 521" rowspan="3">Bright dot</td> <td data-bbox="718 360 1232 416">Random</td> <td data-bbox="1232 360 1481 416">N≤2</td> </tr> <tr> <td data-bbox="718 416 1232 472">2 dots adjacent</td> <td data-bbox="1232 416 1481 472">N≤0</td> </tr> <tr> <td data-bbox="718 472 1232 521">3 dots adjacent</td> <td data-bbox="1232 472 1481 521">N≤0</td> </tr> <tr> <td data-bbox="523 521 718 689" rowspan="3">Dark dot</td> <td data-bbox="718 521 1232 577">Random</td> <td data-bbox="1232 521 1481 577">N≤2</td> </tr> <tr> <td data-bbox="718 577 1232 633">2 dots adjacent</td> <td data-bbox="1232 577 1481 633">N≤0</td> </tr> <tr> <td data-bbox="718 633 1232 689">3 dots adjacent</td> <td data-bbox="1232 633 1481 689">N≤0</td> </tr> <tr> <td data-bbox="523 689 718 999">Distance</td> <td data-bbox="718 689 1232 999"> 1. Minimum Distance Between Bright dots. 2. Minimum Distance Between dark dots 3. Minimum Distance Between dark and bright dot. </td> <td data-bbox="1232 689 1481 999">5mm</td> </tr> <tr> <td colspan="2" data-bbox="523 999 1232 1055">Total bright and dark dot</td> <td data-bbox="1232 999 1481 1055">N≤4</td> </tr> </tbody> </table> <p>Note:</p> <p>A) Bright dot: Dots appear bright and unchanged in size in which LCD panel is displaying under black pattern.</p> <p>B) Dark dot: Dots appear dark and unchanged in size in which LCD panel is displaying under pure red, green, blue picture.</p> <p>C) 2 dot adjacent = 1 pair = 2 dots</p> <p>Picture:</p> <div style="display: flex; justify-content: space-around; align-items: flex-start;"> <div style="text-align: center;">  <p>2 dot adjacent</p> </div> <div style="text-align: center;">  <p>2 dot adjacent</p> </div> </div> <div style="display: flex; justify-content: space-around; align-items: flex-start; margin-top: 20px;"> <div style="text-align: center;">  <p>2 dot adjacent (vertical)</p> </div> <div style="text-align: center;">  <p>2 dot adjacent (slant)</p> </div> </div>	Item	Zone A	Acceptable Qt	Bright dot	Random	N≤2	2 dots adjacent	N≤0	3 dots adjacent	N≤0	Dark dot	Random	N≤2	2 dots adjacent	N≤0	3 dots adjacent	N≤0	Distance	1. Minimum Distance Between Bright dots. 2. Minimum Distance Between dark dots 3. Minimum Distance Between dark and bright dot.	5mm	Total bright and dark dot		N≤4
Item	Zone A	Acceptable Qt																							
Bright dot	Random	N≤2																							
	2 dots adjacent	N≤0																							
	3 dots adjacent	N≤0																							
Dark dot	Random	N≤2																							
	2 dots adjacent	N≤0																							
	3 dots adjacent	N≤0																							
Distance	1. Minimum Distance Between Bright dots. 2. Minimum Distance Between dark dots 3. Minimum Distance Between dark and bright dot.	5mm																							
Total bright and dark dot		N≤4																							

4.0	Line defect (LCD /Polarizer backlight black/white line, scratches, stain)  W: width, L : length N : Count	<table border="1"> <tr> <th rowspan="2">Width(mm)</th> <th rowspan="2">Length(m)</th> <th colspan="3">Acceptable Qty</th> </tr> <tr> <th>A</th> <th>B</th> <th>C</th> </tr> <tr> <td>$\Phi \leq 0.05$</td> <td>Ignore</td> <td colspan="2">Ignore</td> <td rowspan="3">Ignore</td> </tr> <tr> <td>$0.05 < W \leq 0.06$</td> <td>$L \leq 4.0$</td> <td colspan="2">$N \leq 3$</td> </tr> <tr> <td>$0.06 < W \leq 0.08$</td> <td>$L \leq 3.0$</td> <td colspan="2">$N \leq 2$</td> </tr> <tr> <td>$W > 0.08$</td> <td colspan="4">Define as spot defect</td> </tr> </table>	Width(mm)	Length(m)	Acceptable Qty			A	B	C	$\Phi \leq 0.05$	Ignore	Ignore		Ignore	$0.05 < W \leq 0.06$	$L \leq 4.0$	$N \leq 3$		$0.06 < W \leq 0.08$	$L \leq 3.0$	$N \leq 2$		$W > 0.08$	Define as spot defect			
		Width(mm)			Length(m)	Acceptable Qty																						
			A	B		C																						
		$\Phi \leq 0.05$	Ignore	Ignore		Ignore																						
		$0.05 < W \leq 0.06$	$L \leq 4.0$	$N \leq 3$																								
$0.06 < W \leq 0.08$	$L \leq 3.0$	$N \leq 2$																										
$W > 0.08$	Define as spot defect																											
5.0	Electronic Components SMT.	Not allow missing parts, solderless connection, cold solder joint, mismatch, The positive and negative polarity opposite																										
6.0	Display color& Brightness.	1. Color: Measuring the color coordinates, The measurement standard according to the datasheet or samples. 2. Brightness: Measuring the brightness of White screen, The measurement standard according to the datasheet or Samples.																										
7.0	LCD Mura/Waving/ Hot spot	Not visible through 5% ND filter in 50% gray or judge by limit sample if necessary.																										

Criteria (functional items)

Number	Items	Criteria (mm)
1	No display	Not allowed
2	Missing segment	Not allowed
3	Short	Not allowed
4	Backlight no lighting	Not allowed

8. Reliability Test Result

Item	Condition	Inspection after test
High Temperature Operating	70°C,96H	Inspection after 2~4hours storage at room temperature, the sample shall be free from defects: 1.Air bubble in the LCD; 2.Non-display; 3.Missing segments/line; 4.Glass crack; 5.Current IDD is twice higher than initial value.
Low Temperature Operating	-20°C, 96HR	
High Temperature Storage	85°C, 96HR	
Low Temperature Storage	-30°C, 96HR	
High Temperature & High	+60°C, 90% RH ,96 hours.	
Thermal Shock (Non-operation)	-30°C,30 min ↔ +85°C,30 min, Change time:5min 20CYC.	
ESD test	C=150pF, R=330,5points/panel Air:±6KV, 5times; Contact:±4KV, 5 times; (Environment: 15°C~35°C, 30%~60%).	
Vibration (Non-operation)	Frequency range:10~55Hz, Stroke:1.5mm Sweep:10Hz~55Hz~10Hz 2 hours for each direction of X.Y.Z. (6 hours for total) (Package condition).	
Box Drop Test	1 Corner 3 Edges 6 faces,80cm(MEDIUM BOX)	

Remark:

- 1.The test samples should be applied to only one test item.
- 2.Sample size for each test item is 5~10pcs.
- 3.For Damp Proof Test, Pure water(Resistance > 10MΩ) should be used.
- 4.In case of malfunction defect caused by ESD damage, if it would be recovered to normal state after resetting, it would be judged as a good part.
- 5.Failure Judgment Criterion: Basic Specification, Electrical Characteristic, Mechanical Characteristic, Optical Characteristic.

Part. No	KD101WXFLD021-01	REV	V1.1	Page 23 of 25
----------	------------------	-----	------	---------------

常备库存
Stock For Sale

长期供货
Long Time supply

支持小量
NO MOQ

品种齐全
In Full Range

9. Cautions and Handling Precautions

9.1 Handling and Operating the Module

(1) When the module is assembled, it should be attached to the system firmly.

Do not warp or twist the module during assembly work.

(2) Protect the module from physical shock or any force. In addition to damage, this may cause improper operation or damage to the module and back-light unit.

(3) Note that polarizer is very fragile and could be easily damaged. Do not press or scratch the surface.

(4) Do not allow drops of water or chemicals to remain on the display surface.

If you have the droplets for a long time, staining and discoloration may occur.

(5) If the surface of the polarizer is dirty, clean it using some absorbent cotton or soft cloth.

(6) The desirable cleaners are water, IPA (Isopropyl Alcohol) or Hexane.

Do not use ketene type materials (ex. Acetone), Ethyl alcohol, Toluene, Ethyl acid or Methyl chloride. It might permanent damage to the polarizer due to chemical reaction.

(7) If the liquid crystal material leaks from the panel, it should be kept away from the eyes or mouth. In case of contact with hands, legs, or clothes, it must be washed away thoroughly with soap.

(8) Protect the module from static; it may cause damage to the CMOS ICs.

(9) Use finger-stalls with soft gloves in order to keep display clean during the incoming inspection and assembly process.

(10) Do not disassemble the module.

(11) Protection film for polarizer on the module shall be slowly peeled off just before use so that the electrostatic charge can be minimized.

(12) Pins of I/F connector shall not be touched directly with bare hands.

(13) Do not connect, disconnect the module in the "Power ON" condition.

(14) Power supply should always be turned on/off by the item 6.1 Power On Sequence & 6.2 Power Off Sequence

9.2 Storage and Transportation.

(1) Do not leave the panel in high temperature, and high humidity for a long time.

It is highly recommended to store the module with temperature from 0 to 35 °C and relative humidity of less than 70%

(2) Do not store the TFT-LCD module in direct sunlight.

(3) The module shall be stored in a dark place. When storing the modules for a long time, be sure to adopt effective measures for protecting the modules from strong ultraviolet radiation, sunlight, or fluorescent light.

(4) It is recommended that the modules should be stored under a condition where no condensation is allowed. Formation of dewdrops may cause an abnormal operation or a failure of the module.

In particular, the greatest possible care should be taken to prevent any module from being operated where condensation has occurred inside.

(5) This panel has its circuitry FPC on the bottom side and should be handled carefully in order not to be stressed.

Part. No	KD101WXFLD021-01	REV	V1.1	Page 24 of 25
	常备库存 Stock For Sale	长期供货 Long Time supply	支持小量 NO MOQ	品种齐全 In Full Range

10. Packing

----TBD-----

Part. No	KD101WXFLD021-01	REV	V1.1	Page 25 of 25
	常备库存 Stock For Sale	长期供货 Long Time supply	支持少量 NO MOQ	品种齐全 In Full Range